

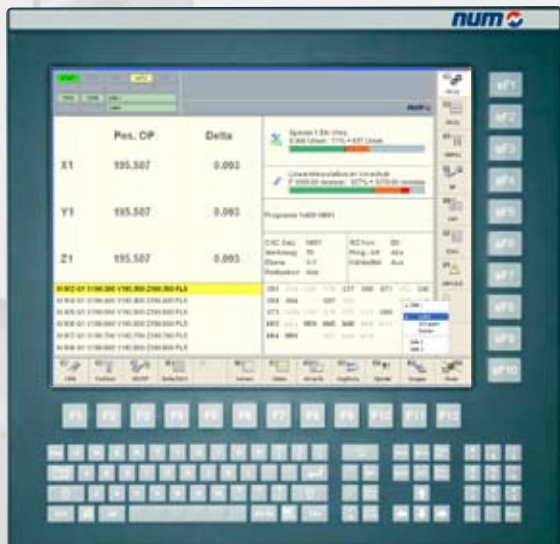

numtransfer®

CNC Complete Solution for Transfer, Rotary-Transfer and Multispindle Machines



- Adaptable to all machines
- NUMtransfer CNC concept
- Machine and process-oriented operating concept
- User interface can be adapted as desired
- Special CAM functions



CNC Complete Solutions for Transfer, Rotary-Transfer and Multispindle Machines

Operating the transfer machines profitably

In mass production, transfer, rotary transfer and multi-spindle machines must be optimised to the parts to be manufactured in order to work in a time-efficient manner. The increasing demand for smaller batches, a greater variety and faster response times places increasingly greater requirements on the setup, conversion and handling

of these machines. The profitable use of these machines therefore requires flexibility and efficient, intuitive operation that is transparent to the user.

Practice-oriented CNC total solution

NUM has been supplying CNC systems that are used successfully around the world for many years. Based on the wealth of experience it has gained, the NUMtransfer CNC has been devel-

oped and optimally adapted to the demands of the transfer, rotary transfer and multi-spindle machines.

Securing investments

Further development of NUMtransfer to meet the requirements of users secures the investments made by machine manufacturers and machine users.

They can be expanded as desired and adapted to the machine and users' needs

- more than 40 stations
- more than 150 interpolated CNC axes
- up to 128 positioning axes
- Multi-CNC operation for controlling any number of axes/stations
- Assignment or switchover of a C-axis to various axis groups
- Integration of continuous rotating tables

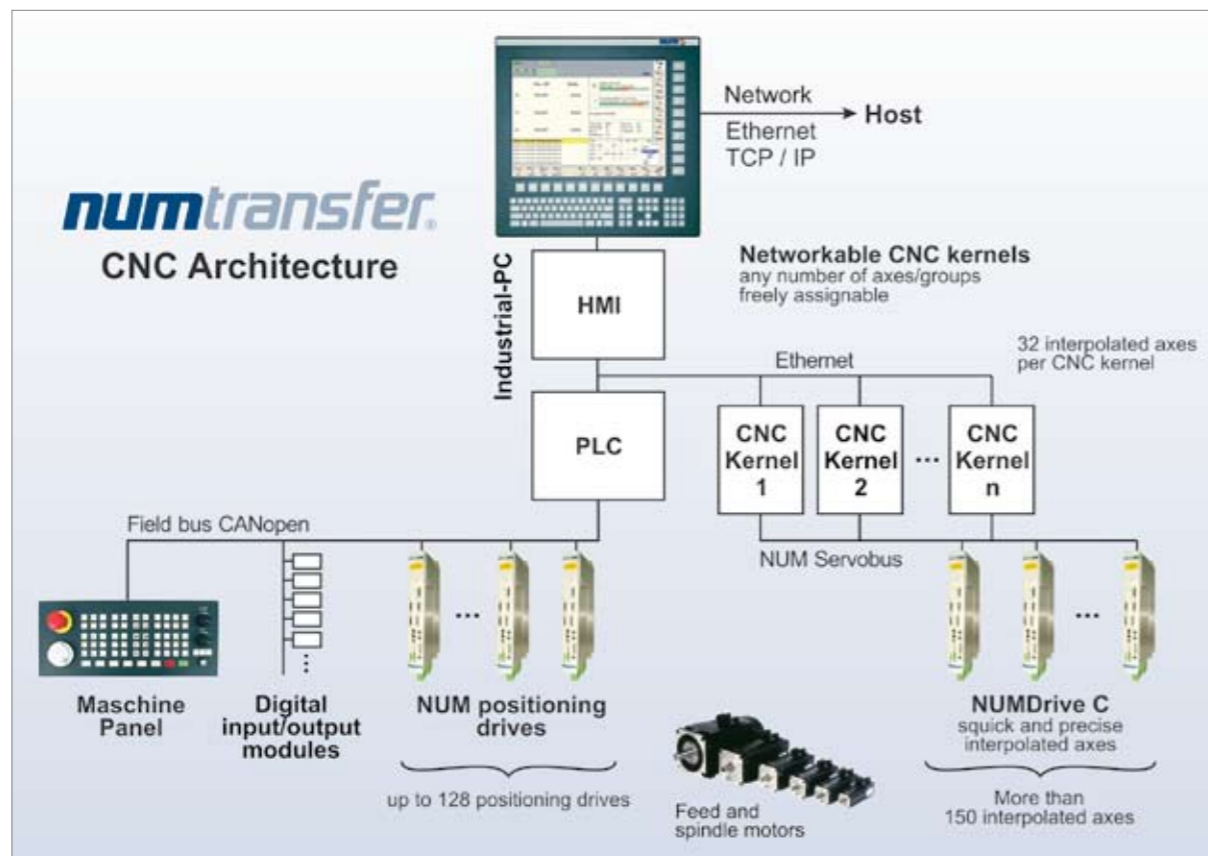

Machine and process-oriented operating concept

Due to the parametrisation, transfer machines from simple to highly complex are easily understood by the operator and are depicted just as they are operated. The names of the stations can be freely assigned and thereby clearly and quickly identified.

For very large machines, the stations can be combined into "cells", which can likewise be assigned any name. Every station and every cell can be directly selected in any operating mode of the CNC system. The operator selects the corresponding function and does

not have to bother about which CNC channel and which CNC executes these functions. This provides an improved overview, increases operating speed and reduces inputting errors. Comprehensive and precise error messages facilitates machine downtime.

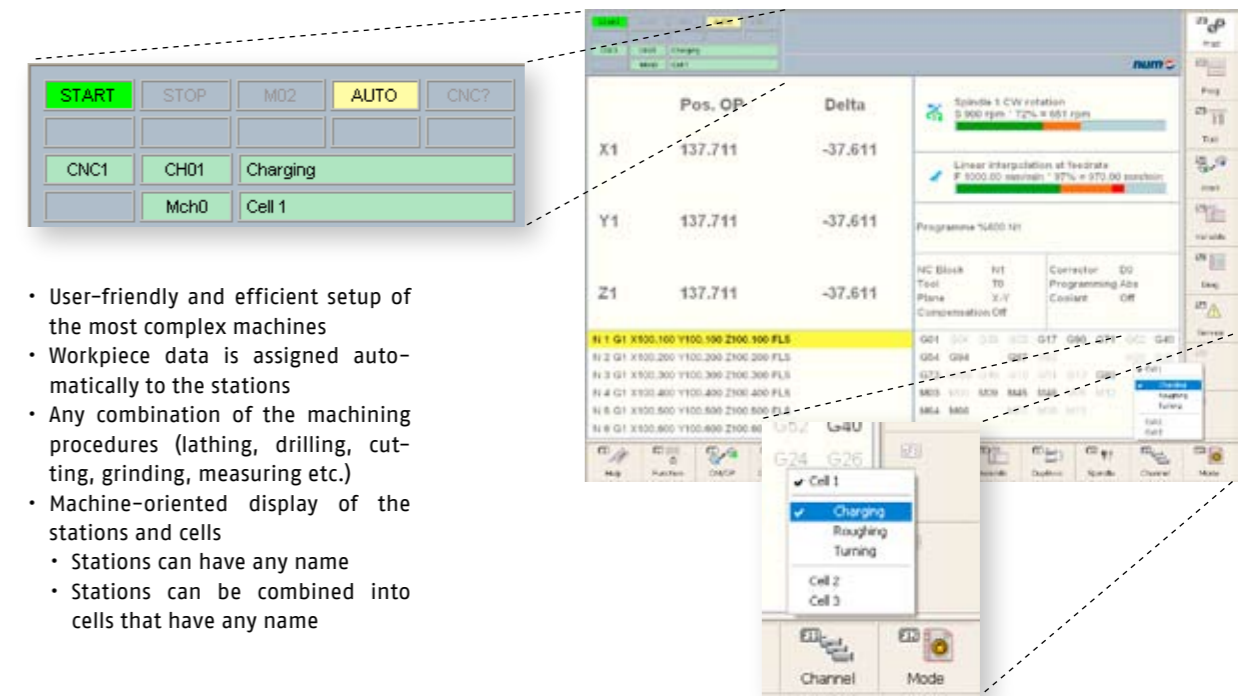

- User-friendly and efficient setup of the most complex machines
- Workpiece data is assigned automatically to the stations
- Any combination of the machining procedures (lathing, drilling, cutting, grinding, measuring etc.)
- Machine-oriented display of the stations and cells
 - Stations can have any name
 - Stations can be combined into cells that have any name

User interface that can be configured as desired

Besides the standard configuration options, the user interface can be adapted with the NUMpass HMI to meet the needs of special requirements. The modular structure of the software and the special tools available, make it possible to easily implement and modify special functions in a real-time application. Thus, the capabilities of the machine can be fully utilised, and the operating functions can be adapted to the part families to be machined.

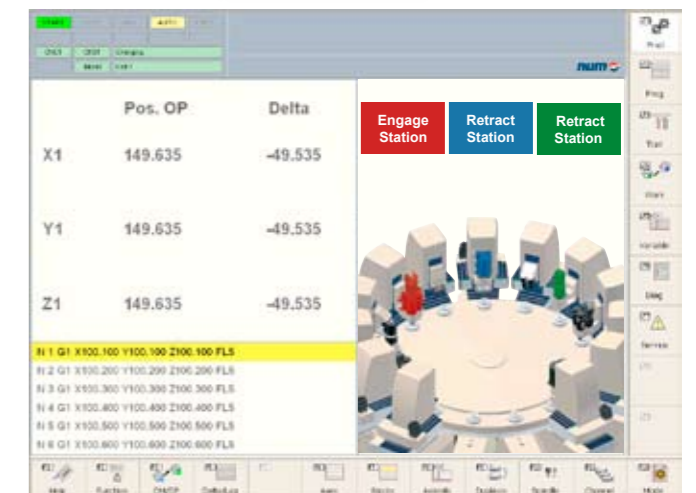

Special CAM functions in NUMtransfer

Automatic assignment of the machining stations to the CNC groups.

- Ability to import IGES, DFX and other data formats from any CAD system
- Time-optimised distribution of machining operations to the individual machining stations

With the built-in modularity and flexibility of the software, which is provided for additional desired features, the development and adaptation of special CAM functions can be easily implemented.

CNC Power Engineering Always on the move

NUM competence centers for CNC high-end applications:

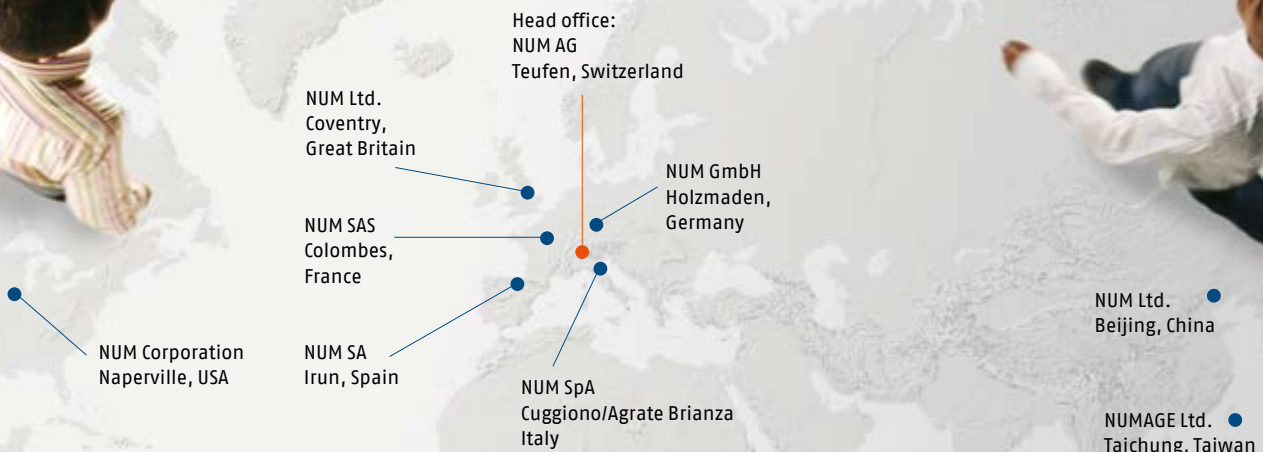

NUM:

A European company active on
a global scale.

Your specialist for CNC total solutions

- Transfer, rotary-transfer and multispindle machines: NUMtransfer
- Tool grinding: NUMROTO
- Gear hobbing: NUMgear
- 5-axis machining for HSC and mould construction
- Woodworking
- Special machines for the car industry
- Wide range of solutions for machines retrofit

NUMtransfer 03/07 en

© 2007 NUM AG – All rights reserved